

**Digital thermostat
XW10L**

1. GENERAL WARNING

1.1 PLEASE READ BEFORE USING THIS MANUAL

- This manual is part of the product and should be kept near the instrument for easy and quick reference.
- The instrument shall not be used for purposes different from those described hereunder. It cannot be used as a safety device.
- Check the application limits before proceeding.
- Dixell Srl reserves the right to change the composition of its products, even without notice, ensuring the same and unchanged functionality.

1.2 SAFETY PRECAUTIONS

- Check the supply voltage is correct before connecting the instrument.
- Do not expose to water or moisture: use the controller only within the operating limits avoiding sudden temperature changes with high atmospheric humidity to prevent formation of condensation
- Warning: disconnect all electrical connections before any kind of maintenance.
- Fit the probe where it is not accessible by the End User. The instrument must not be opened.
- In case of failure or faulty operation send the instrument back to the distributor or to "Dixell S.p.A." (see address) with a detailed description of the fault.
- Consider the maximum current which can be applied to each relay (see Technical Data).
- Ensure that the wires for probes, loads and the power supply are separated and far enough from each other, without crossing or intertwining.
- In case of applications in industrial environments, the use of mains filters (our mod. FT1) in parallel with inductive loads could be useful.

2. GENERAL DESCRIPTION

Model XW10L, format 38x185mm, is a digital thermostat designed for refrigeration applications at normal temperature. It has 2 relay outputs to control thermostat and light (configurable). A "Day and Night" function with two different set points is fitted for energy saving. It is also provided with up to four NTC or PTC probe inputs, the first one for temperature control, the second one for display temperature of another point. One of the 2 digital inputs can operate as third temperature probe. The fourth probe is used to signal the condenser temperature alarm or to display a temperature. The HOT KEY output allows to connect the unit, by means of the external module XJ485-CX, to a network line ModBUS-RTU compatible such as the dixell monitoring units of X-WEB family. It allows to program the controller by means the HOT KEY programming keyboard. The instrument is fully configurable through special parameters that can be easily programmed through the keyboard.

3. CONTROLLING LOADS

3.1 THE REGULATION OUTPUT

The regulation is performed according to the temperature measured by the probe. The instruments are provided with the CH programmable parameter which enables the user to set the regulation both for heating or cooling applications:
 - CH = CL: cooling applications
 - CH = Ht: heating applications

3.2 CH = CL: COOLING APPLICATIONS.

The Hy value is automatically set above the Set Point. If the temperature increases and reaches set point plus differential the compressor is started and then turned off when the temperature reaches the set point value again.

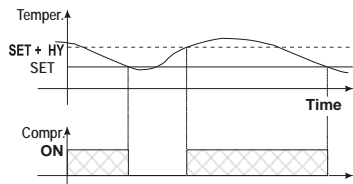

In case of fault in the thermostat probe the start and stop of the compressor are timed through parameters "COOn" and "COF".

3.3 CH = HT: HEATING APPLICATION.

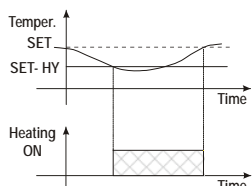

The Hy value is automatically set under the Set Point. If the temperature decreases and reaches set point minus differential the regulation output is activated and then turned off when the temperature reaches the set point value again.

3.4 LIGHT RELAY CONFIGURATION

The functioning of the auxiliary relay (terminals 1-3) can be set by the oA3 parameter, according to the kind of application. In the following paragraph the possible setting:

3.4.1 Auxiliary thermostat

I.E.. anti condensing heater) with the possibility of switching it on and off also by keyboard

Parameters involved:

- ACH Kind of regulation for the auxiliary relay: Ht: heating; cL: cooling;
- SAA Set point for auxiliary relay
- SHy Differential for auxiliary relay
- ArP Probe for auxiliary relay
- Sdd Auxiliary output off during defrost

By means of these 5 parameters the functioning of the auxiliary relay can be set.. The differential is given by the SHy parameter. The auxiliary relay can be switched on also by the AUX button. In this case it remains on till it's manually switched off.

NOTE: Set oA3 =AUS and ArP= nP (no probe for auxiliary output). In this case the relay 1-3 can be activated only by digital input with i1F or i2F = AUS.

3.4.2 On/off relay – oA3 = onF

In this case the relay is activated when the controller is turned on and de-activated when the controller is turned off.

3.4.3 Neutral zone regulation

With oA3 = db the relay 1-3 can control a heater element to perform a neutral zone action. oA3 cut in = SET-HY oA3 cut out = SET

3.4.4 Second compressor

With oA3 = CP2, the relay 1-3 operates as second compressor: it is activated in parallel with the relay of the first compressor, with a possible delay set in the AC1 parameter. Both the compressors are switched off at the same time.

3.4.5 Alarm relay

With oA3 = ALr the relay 1-3 operates as alarm relay. It is activated every time an alarm happens. Its status depends on the tbA parameter: if "tbA = y", the relay is silenced by pressing any key. If "tbA = n", the alarm relay remains on until the alarm condition recovers.

3.4.6 Night blind management during energy saving cycles

With oA3 = HES, the relay 1-3 operates to manage the night blind: the relay is energised when the energy saving cycle is activated, by digital input, frontal button or RTC (optional)

4. FRONT PANEL COMMANDS

4.1 STANDARD FRONTAL PANEL



4.2 STEEL FINISHING



SET: To display target set point; in programming mode it selects a parameter or confirm an operation.

(DEF) NOT USED

(UP): To see the max. stored temperature; in programming mode it browses the parameter codes or increases the displayed value.

(DOWN) To see the min stored temperature; in programming mode it browses the parameter codes or decreases the displayed value.

To switch the instrument off, if onF = oFF.

To switch the light, if oA3 = Lig.

KEY COMBINATIONS:

+ To lock & unlock the keyboard.

SET + To enter in programming mode.

SET + To return to the room temperature display.

4.3 USE OF LEDS

Each LED function is described in the following table.

LED	MODE	FUNCTION
	ON	Compressor enabled
	Flashing	Anti-short cycle delay enabled

LED	MODE	FUNCTION
	ON	An alarm is occurring
	ON	Continuous cycle is running
	ON	Energy saving enabled
	ON	Light on
ALU	ON	Auxiliary relay on
°C/°F	ON	Measurement unit
°C/°F	Flashing	Programming phase

5. MAX & MIN TEMPERATURE MEMORIZATION

5.1 HOW TO SEE THE MIN TEMPERATURE

1. Press and release the \blacktriangledown key.
2. The "Lo" message will be displayed followed by the minimum temperature recorded.
3. By pressing the \blacktriangledown key again or by waiting 5s the normal display will be restored.

5.2 HOW TO SEE THE MAX TEMPERATURE

1. Press and release the \blacktriangle key.
2. The "Hi" message will be displayed followed by the maximum temperature recorded.
3. By pressing the \blacktriangle key again or by waiting 5s the normal display will be restored.

5.3 HOW TO RESET THE MAX AND MIN TEMPERATURE RECORDED

1. Hold press the SET key for more than 3s, while the max. or min temperature is displayed. (rSt message will be displayed)
2. To confirm the operation the "rSt" message starts blinking and the normal temperature will be displayed.

6. MAIN FUNCTIONS

6.1 HOW TO SEE THE SET POINT

- SET
1. Push and immediately release the SET key: the display will show the Set point value;
 2. Push and immediately release the SET key or wait for 5 seconds to display the probe value again.

6.2 HOW TO CHANGE THE SET POINT

1. Push the SET key for more than 2 seconds to change the Set point value;
2. The value of the set point will be displayed and the "°C" or "°F" LED starts blinking;
3. To change the Set value push the \blacktriangle or \blacktriangledown arrows within 10s.
4. To memorise the new set point value push the SET key again or wait 10s.

6.3 HOW TO CHANGE A PARAMETER VALUE

To change the parameter's value operate as follows:

1. Enter the Programming mode by pressing the Set + \blacktriangledown keys for 3s (the "°C" or "°F" LED starts blinking).
2. Select the required parameter. Press the "SET" key to display its value
3. Use "UP" or "DOWN" to change its value.
4. Press "SET" to store the new value and move to the following parameter.

To exit: Press SET + UP or wait 15s without pressing a key.

NOTE: the set value is stored even when the procedure is exited by waiting the time-out to expire.

6.4 THE HIDDEN MENU

The hidden menu includes all the parameters of the instrument.

6.4.1 HOW TO ENTER THE HIDDEN MENU

1. Enter the Programming mode by pressing the Set + \blacktriangledown keys for 3s (the "°C" or "°F" LED starts blinking).
2. Released the keys, then push again the Set+ \blacktriangledown keys for more than 7s. The Pr2 label will be displayed immediately followed from the HY parameter.
NOW YOU ARE IN THE HIDDEN MENU.
3. Select the required parameter.
4. Press the "SET" key to display its value
5. Use \blacktriangle or \blacktriangledown to change its value.
6. Press "SET" to store the new value and move to the following parameter.

To exit: Press SET + \blacktriangle or wait 15s without pressing a key.

NOTE1: if none parameter is present in Pr1, after 3s the "noP" message is displayed. Keep the keys pushed till the Pr2 message is displayed.

NOTE2: the set value is stored even when the procedure is exited by waiting the time-out to expire.

6.4.2 HOW TO MOVE A PARAMETER FROM THE HIDDEN MENU TO THE FIRST LEVEL AND VICEVERSA.

Each parameter present in the HIDDEN MENU can be removed or put into "THE FIRST LEVEL" (user level) by pressing "SET + \blacktriangledown ".

In HIDDEN MENU when a parameter is present in First Level the decimal point is on.

6.5 HOW TO LOCK THE KEYBOARD

1. Keep pressed for more than 3 s the UP + DOWN keys.
2. The "POF" message will be displayed and the keyboard will be locked. At this point it will be possible only to see the set point or the MAX o Min temperature stored
3. If a key is pressed more than 3s the "POF" message will be displayed.

6.6 TO UNLOCK THE KEYBOARD

Keep pressed together for more than 3s the \blacktriangle and \blacktriangledown keys, till the "Pon" message will be displayed.

6.7 THE CONTINUOUS CYCLE

It can be activated by holding the "▲" key pressed for about 3 seconds. The compressor operates to maintain the "ccS" set point for the time set through the "CCt" parameter. The cycle can be terminated before the end of the set time using the same activation key "▲" for 3 seconds.

6.8 THE ON/OFF FUNCTION



With "onF = oFF", pushing the ON/OFF key, the instrument is switched off. The "OFF" message is displayed. In this configuration, the regulation is disabled.

To switch the instrument on, push again the ON/OFF key.

WARNING: Loads connected to the normally closed contacts of the relays are always supplied and under voltage, even if the instrument is in stand by mode.

7. PARAMETERS

REGULATION

Hy Differential: (0.1 ÷ 25.5°C / 1÷255 °F) Intervention differential for set point. Compressor Cut IN is Set Point + differential (Hy). Compressor Cut OUT is when the temperature reaches the set point.

LS Minimum set point: (-50°C÷SET/-58°F÷SET): Sets the minimum value for the set point.

US Maximum set point: (SET÷110°C/SET÷230°F). Set the maximum value for set point.

Ot Thermostat probe calibration: (-12.0÷12.0°C; -120÷120°F) allows to adjust possible offset of the thermostat probe.

P2P Second probe presence: n= not present; y= present.

OE Second probe calibration: (-12.0÷12.0°C; -120÷120°F). allows to adjust possible offset of the second probe.

P3P Third probe presence (P3): n= not present.; the terminals 13-14 operate as digital input.; y= present.; the terminals 13-14 operate as third probe.

O3 Third probe calibration (P3): (-12.0÷12.0°C; -120÷120°F). allows to adjust possible offset of the third probe.

P4P Fourth probe presence: (n = Not present; y = present).

o4 Fourth probe calibration: (-12.0÷12.0°C) allows to adjust possible offset of the fourth probe.

Ods Outputs activation delay at start up: (0÷255min) This function is enabled at the initial start up of the instrument and inhibits any output activation for the period of time set in the parameter.

AC Anti-short cycle delay: (0÷50 min) minimum interval between the compressor stop and the following restart.

AC1 2nd compressor delay at start up (0÷255s) Used only if oA3 = cP2 Time interval between the switching on of the first compressor and the second one.

rtr Percentage of the second and first probe for regulation (0÷100; 100 = P1, 0 = P2); it allows to set the regulation according to the percentage of the first and second probe, as for the following formula (rtr(P1-P2)/100 + P2).

CCt Compressor ON time during continuous cycle: (0.0÷24.0h; res. 10min) Allows to set the length of the continuous cycle: compressor stays on without interruption for the CCt time. Can be used, for instance, when the room is filled with new products.

CCS Set point for continuous cycle: (-50÷150°C) it sets the set point used during the continuous cycle.

CO n Compressor ON time with faulty probe: (0÷255 min) time during which the compressor is active in case of faulty thermostat probe. With CO n=0 compressor is always OFF.

COF Compressor OFF time with faulty probe: (0÷255 min) time during which the compressor is OFF in case of faulty thermostat probe. With COF=0 compressor is always active.

CH Type of action: CL = cooling; Ht = heating.

DISPLAY

CF Temperature measurement unit: °C=Celsius; °F=Fahrenheit. WARNING: When the measurement unit is changed the SET point and the values of the parameters Hy, LS, US, Ot, ALU and ALL have to be checked and modified if necessary).

rES Resolution (for °C): (in = 1°C; dE = 0.1 °C) allows decimal point display.

Lod Instrument display: (P1; P2, P3, P4, SET, dtr): it selects which probe is displayed by the instrument: P1 = Thermostat probe; P2 = Second probe; P3 = Third probe(only for model with this option enabled); P4 = Fourth probe, SET = set point; dtr = percentage of visualization.

rEd X- REP display (optional): (P1; P2, P3, P4, SET, dtr): it selects which probe is displayed by X- REP: P1 = Thermostat probe; P2 = Second probe; P3 = Third probe(only for model with this option enabled); P4 = Fourth probe, SET = set point; dtr = percentage of visualization.

dLy Display delay: (0 ÷20.0m; resul. 10s) when the temperature increases, the display is updated of 1 °C/1°F after this time.

dtr Percentage of the second and first probe for visualization when Lod = dtr (0÷100; 100 = P1, 0 = P2); if Lod = dtr it allows to set the visualization according to the percentage of the first and second probe, as for the following formula (dtr(P1-P2)/100 + P2).

AUXILIARY THERMOSTAT CONFIGURATION (terms. 1-3) - OA3 = AUS

ACH Kind of regulation for auxiliary relay: Ht = heating; CL = cooling

SA A Set Point for auxiliary relay: (-50.0÷110.0°C; -58÷230°F) it defines the room temperature set point to switch auxiliary relay.

SHy Differential for auxiliary output: (0.1 ÷ 25.5°C / 1÷255 °F) Intervention differential for auxiliary output set point.

With ACH = cL AUX Cut in is SAA + SHy; . AUX Cut out is SAA

With ACH = Ht AUX Cut in is SAA - SHy; . AUX Cut out is SAA

ArP Probe selection for auxiliary: nP = no probe, the auxiliary relay is switched only by button; P1 = Probe 1 (Thermostat probe); P2 = Probe 2 (second probe); P3 = Probe 3 (display probe); P4 = Probe 4 fourth probe.

Sdd Auxiliary relay off during defrost: n = the auxiliary relay operates during defrost.

y = the auxiliary relay is switched off during defrost.

ALARMS

ALP Probe selection for alarm: nP = no probe, the temperature alarms are disabled; P1 = Probe 1 (Thermostat probe); P2 = Probe 2 (second probe); P3 = Probe 3 (display probe); P4 = Fourth probe.

ALC Temperature alarms configuration: (Ab; rE)

Ab= absolute temperature: alarm temperature is given by the ALL or ALU values. rE = temperature alarms are referred to the set point. Temperature alarm is enabled when the temperature exceeds the "SET+ALU" or "SET-ALL" values.

ALU MAXIMUM temperature alarm: (SET÷110°C; SET÷230°F) when this temperature is reached the alarm is enabled, after the "ALd" delay time.

ALL Minimum temperature alarm: (-50.0 ÷ SET °C; -58÷230°F when this temperature is reached the alarm is enabled, after the "ALd" delay time.
AFH Differential for temperature alarm recovery: (0,1÷25,5°C; 1÷45°F) Intervention differential for recovery of temperature alarm.
ALd Temperature alarm delay: (0÷255 min) time interval between the detection of an alarm condition and alarm signalling.
dAo Exclusion of temperature alarm at start-up: (from 0.0 min to 23.5h) time interval between the detection of the temperature alarm condition after instrument power on and alarm signalling.

CONDENSER TEMPERATURE ALARM

AP2 Probe selection for temperature alarm of condenser: nP = no probe; P1 = thermostat probe; P2 = second probe; P3 = configurable probe; P4 = Probe on Hot Key plug.
AL2 Low temperature alarm of condenser: (-55÷150°C) when this temperature is reached the LA2 alarm is signalled, possibly after the Ad2 delay.
Au2 High temperature alarm of condenser: (-55÷150°C) when this temperature is reached the HA2 alarm is signalled, possibly after the Ad2 delay.
AH2 Differential for temperature condenser alarm recovery: (0,1÷25,5°C; 1÷45°F)
Ad2 Condenser temperature alarm delay: (0÷255 min) time interval between the detection of the condenser alarm condition and alarm signalling.
dA2 Condenser temperature alarm exclusion at start up: (from 0.0 min to 23.5h, res. 10min)
bLL Compressor off with low temperature alarm of condenser: n = no: compressor keeps on working; Y = yes, compressor is switched off till the alarm is present, in any case regulation restarts after AC time at minimum.
AC2 Compressor off with high temperature alarm of condenser: n = no: compressor keeps on working; Y = yes, compressor is switched off till the alarm is present, in any case regulation restarts after AC time at minimum.

AUXILIARY RELAY

tbA Alarm relay silencing (with oA3 = ALr):
 n = silencing disabled: alarm relay stays on till alarm condition lasts,
 y = silencing enabled: alarm relay is switched OFF by pressing a key during an alarm
oA3 Third relay configuration (1-3): dEF, FAn: do not select it!. ALr: alarm; Lig: light; AuS: Auxiliary relay; onF: always on with instrument on; dB = NOT USED; AUS = neutral zone; cP2 = second compressor; dEF2: do not select it!.; HES.: night blind
AoP Alarm relay polarity: it set if the alarm relay is open or closed when an alarm happens. CL = terminals 1-3 closed during an alarm; oP = terminals 1-3 open during an alarm

DIGITAL INPUTS

i1P Digital input polarity (13-14): oP: the digital input is activated by opening the contact; CL: the digital input is activated by closing the contact.
i1F Digital input configuration (13-14): EAL = external alarm: "EA" message is displayed; bAL = serious alarm "CA" message is displayed. PAL = pressure switch alarm, "CA" message is displayed; dor = door switch function; dEF = NOT USED; AUS = not enabled; Htr = kind of action inversion (cooling - heating); FAn = not set it; ES = Energy saving; HdF = NOT USED; onF = to switch the controller off.
did (0÷255 min) with i1F = EAL or i1F = bAL digital input alarm delay (13-14): delay between the detection of the external alarm condition and its signalling.
 with i1F = dor: door open signalling delay
 with i1F = PAL: time for pressure switch function: time interval to calculate the number of the pressure switch activation.
i2P 2nd digital input polarity (13-19): oP: the digital input is activated by opening the contact; CL: the digital input is activated by closing the contact.
i2F 2nd digital input configuration (13-19): EAL = external alarm: "EA" message is displayed; bAL = serious alarm "CA" message is displayed. PAL = pressure switch alarm, "CA" message is displayed; dor = door switch function; dEF = NOT USED; AUS = not enabled; Htr = kind of action inversion (cooling - heating); FAn = not set it; ES = Energy saving; HdF = NOT USED; onF = to switch the controller off.
d2d (0÷255 min) with i2F = EAL or i2F = bAL 2nd digital input alarm delay (13-19): delay between the detection of the external alarm condition and its signalling.
 with i2F = dor: door open signalling delay
 with i2F = PAL: time for pressure switch function: time interval to calculate the number of the pressure switch activation.
nPS Pressure switch number: (0 ÷15) Number of activation of the pressure switch, during the "did" interval, before signalling the alarm event (i2F = PAL).
 If the nPS activation in the did time is reached, switch off and on the instrument to restart normal regulation.
odc Compressor status when open door: no, Fan = normal; CPr, F_C = Compressor OFF.
rrd Outputs restart after doA alarm: no = outputs not affected by the doA alarm; yES = outputs restart with the doA alarm.
HES Temperature increase during the Energy Saving cycle: (-30,0°C÷30,0°C) it sets the increasing value of the set point during the Energy Saving cycle.

OTHER

Adr Serial address (1÷244): Identifies the instrument address when connected to a ModBUS compatible monitoring system.
PbC Type of probe: it allows to set the kind of probe used by the instrument: PbC = PBC probe, ntc = NTC probe.
onF on/off key enabling: nu = disabled; oFF = enabled; ES = not set it.
dP1 Thermostat probe display
dP2 Second probe display
dP3 Third probe display - optional
dP4 Fourth probe display.
rSE Real set point: it shows the set point used during the energy saving cycle or during the continuous cycle.
rEL Software release for internal use.
Ptb Parameter table code: readable only.

8. DIGITAL INPUTS

The first digital input 13-14 is enabled with P3P = n.
 With P3P = n and i1F = i2F the second digital input is disabled
 The free voltage digital inputs are programmable by the "i1F" and i2F parameters.

8.1 GENERIC ALARM (i1F or i2F = EAL)

As soon as the digital input is activated the unit will wait for "did" time delay before signalling the "EAL" alarm message. The outputs status don't change. The alarm stops just after the digital input is de-activated.

8.2 SERIOUS ALARM MODE (i1F or i2F = bAL)

When the digital input is activated, the unit will wait for "did" delay before signalling the "CA" alarm message. The relay outputs are switched OFF. The alarm will stop as soon as the digital input is de-activated.

8.3 PRESSURE SWITCH (i1F or i2F = PAL)

If during the interval time set by "did" parameter, the pressure switch has reached the number of activation of the "nPS" parameter, the "CA" pressure alarm message will be displayed. The compressor and the regulation are stopped. When the digital input is ON the compressor is always OFF. If the nPS activation in the did time is reached, switch off and on the instrument to restart normal regulation.

8.4 DOOR SWITCH INPUT (i1F or i2F = dor)

It signals the door status and the corresponding relay output status through the "odc" parameter: no, Fan = normal (any change); CPr, F_C = Compressor OFF.
 Since the door is opened, after the delay time set through parameter "did", the door alarm is enabled, the display shows the message "dA" and the regulation restarts is rtr = yES. The alarm stops as soon as the external digital input is disabled again. With the door open, the high and low temperature alarms are disabled.

8.5 SWITCH THE AUXILIARY RELAY (i1F or i2F = AUS)

With oA3 = AUS the digital input switched the status of the auxiliary relay

8.6 INVERSION OF THE KIND OF ACTION: HEATING-COOLING (i1F or i2F = Htr)

This function allows to invert the regulation of the controller: from cooling to heating and viceversa.

8.7 ENERGY SAVING (i1F = ES)

The Energy Saving function allows to change the set point value as the result of the SET+ HES (parameter) sum. This function is enabled until the digital input is activated.

8.8 ON OFF FUNCTION (i1F or i2F = onF)

To switch the controller on and off.

8.9 DIGITAL INPUTS POLARITY

The digital input polarity depends on the "i1P" and "i2P" parameters.
 i1P or i2P = CL: the input is activated by closing the contact.
 i1P or i2P = OP: the input is activated by opening the contact

9. TTL SERIAL LINE - FOR MONITORING SYSTEMS

The TTL serial line, available through the HOT KEY connector, allows by means of the external TTL/RS485 converter, XJ485-CX, to connect the instrument to a monitoring system ModBUS-RTU compatible such as the X-WEB500/3000/300.

10. X-REP OUTPUT - OPTIONAL

As optional, an X-REP can be connected to the instrument, through the dedicated connector.



To connect the X-REP to the instrument the following connectors must be used CAB/REP1 (1m), CAB/REP2 (2m), CAB/REP5 (5m),

11. INSTALLATION AND MOUNTING

The controller XW10L, shall be mounted on vertical panel, in a 150x31 mm hole, and fixed using two screws Ø 3 x 2mm. To obtain an IP65 protection grade use the front panel rubber gasket (mod. RG-L). The temperature range allowed for correct operation is 0 - 60 °C. Avoid places subject to strong vibrations, corrosive gases, excessive dirt or humidity. The same recommendations apply to probes. Let the air circulate by the cooling holes.

11.1 CUT OUT

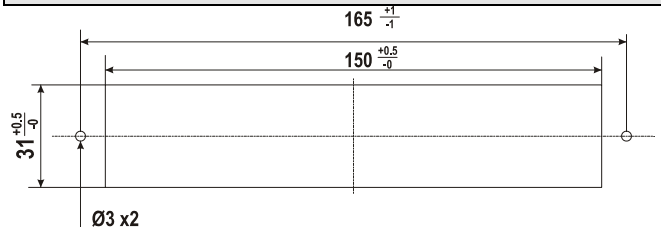

11.2 STEEL FINISHING MOUNTING

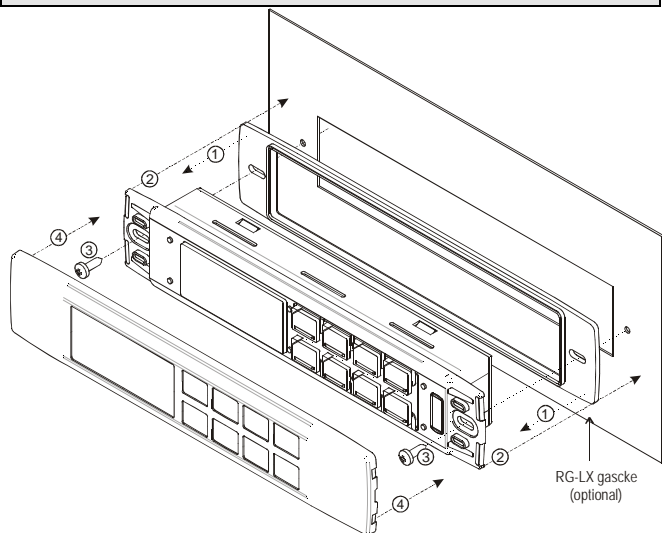

12. ELECTRICAL CONNECTIONS

The instruments are provided with screw terminal block to connect cables with a cross section up to 2,5 mm² for the digital and analogue inputs. Relays and power supply have a Faston connection (6,3mm). Heat-resistant cables have to be used. Before connecting cables make sure the power supply complies with the instrument's requirements. Separate the probe cables from the power supply cables, from the outputs and the power connections. Do not exceed the maximum current allowed on each relay, in case of heavier loads use a suitable external relay.
N.B. Maximum current allowed for all the loads is 20A.

12.1 PROBE CONNECTION

The probes shall be mounted with the bulb upwards to prevent damages due to casual liquid infiltration. It is recommended to place the thermostat probe away from air streams to correctly measure the average room temperature.

13. HOW TO USE THE HOT KEY

13.1 HOW TO PROGRAM A HOT KEY FROM THE INSTRUMENT (UPLOAD)

1. Program one controller with the front keypad.
2. When the controller is **ON**, insert the "Hot key" and push **▲** key; the "uPL" message appears followed a by flashing "End"
3. Push "SET" key and the End will stop flashing.
4. Turn OFF the instrument remove the "Hot Key", then turn it ON again.

NOTE: the "Err" message is displayed for failed programming. In this case push again **▲** key if you want to restart the upload again or remove the "Hot key" to abort the operation.

13.2 HOW TO PROGRAM AN INSTRUMENT USING A HOT KEY (DOWNLOAD)

1. Turn OFF the instrument.
2. Insert a programmed "Hot Key" into the 5 PIN receptacle and then turn the Controller ON.
3. Automatically the parameter list of the "Hot Key" is downloaded into the Controller memory, the "dOL" message is blinking followed a by flashing "End".
4. After 10 seconds the instrument will restart working with the new parameters.
5. Remove the "Hot Key".

NOTE: the message "Err" is displayed for failed programming. In this case turn the unit off and then on if you want to restart the download again or remove the "Hot key" to abort the operation.

14. ALARM SIGNALS

Message	Cause	Outputs
P1	Room probe failure	Compressor output acc. to par. "Con" and "COF"
P2	Second probe failure	Outputs unchanged
P3	Third probe failure	Outputs unchanged
P4	Fourth probe failure	Outputs unchanged
HA	Maximum temperature alarm	Outputs unchanged.
LA	Minimum temperature alarm	Outputs unchanged.
HA2	Condenser high temperature	It depends on the "Ac2" parameter
LA2	Condenser low temperature	It depends on the "bLL" parameter
dA	Door open	Compressor and fans restarts
EA	External alarm	Output unchanged.
CA	Serious external alarm (i1F=bAL)	All outputs OFF.
CA	Pressure switch alarm (i1F=PAL)	All outputs OFF

14.1 SILENCING BUZZER / ALARM RELAY OUTPUT

If ***tBA = y***, the buzzer and the relay are silenced by pressing any key.
 If ***tBA = n***, only the buzzer is silenced while the alarm relay is on until the alarm condition recovers.

14.2 ALARM RECOVERY

Probe alarms P1*, P2*, P3* and P4* start some seconds after the fault in the related probe; they automatically stop some seconds after the probe restarts normal operation. Check connections before replacing the probe.

Temperature alarms "HA", "LA", "HA2" and "LA2" automatically stop as soon as the temperature returns to normal values.

Alarms "EA" and "CA" (with i1F=bAL) recover as soon as the digital input is disabled.

Alarm "CA" (with i1F=PAL) recovers only by switching off and on the instrument.

14.3 OTHER MESSAGES

Pon	Keyboard unlocked.
PoF	Keyboard locked
noP	In programming mode: none parameter is present in Pr1 On the display or in dP2, dP3, dP4: the selected probe is nor enabled

15. TECHNICAL DATA

Housing: self extinguishing ABS.

Case: facia 38x185 mm; depth 76mm

Mounting : panel mounting in a 150x31 mm panel cut-out with two screws. \varnothing 3 x 2mm.
 Distance between the holes 165mm

Protection: IP20; Frontal protection: IP65 with frontal gasket mod RG-L. (optional)

Connections: Screw terminal block \leq 2,5 mm² heat-resistant wiring and 6,3mm Faston

Power supply: 230Vac or. 110Vac or 24Vac \pm 10%

Power absorption: 5VA max.

Display: 3 digits, red LED, 14,2 mm high.

Display: 3 digits, red LED, 14,2 mm high; Inputs: Up to 4 NTC or PTC probes.

Digital inputs: 2 free voltage

Relay outputs: **Total current on loads MAX. 20A**

compressor: relay SPST 20(8) A, 250Vac

light: relay SPST 8 or 16(3) A, 250Vac

Other output : buzzer (optional)

Serial output : TTL standard; Communication protocol: Modbus - RTU

Data storing : on the non-volatile memory (EEPROM).

Internal clock back-up: 24 hours (only for model with RTC)

Kind of action: 1B; Pollution grade: 2; Software class: A;

Rated impulsive voltage: 2500V; Over voltage Category: II

Operating temperature: 0-60 °C; Storage temperature: -30-85 °C.

Relative humidity: 20-85% (no condensing)

Measuring and regulation range: NTC probe: -40-+110°C (-40-+230°F);

PTC probe: -50-+150°C (-58-+302°F)

Resolution: 0,1 °C or 1 °C or 1 °F (selectable); Accuracy (ambient temp. 25°C): \pm 0,7 °C \pm 1 digit

16. CONNECTIONS

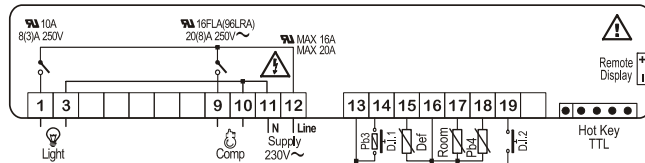

Supply: 120Vac or 24Vac: connect to terminals 11-12

The X-REP output is optional

The light relay can be also 16(5)A according to the model

17. DEFAULT SETTING VALUES

Label	Name	Range	Value	Level
Set	Set point	LS=US	3.0	---
Hy	Differential	0,1-25,5°C / 1-255°F	2.0	Pr1
LS	Minimum set point	-50°C+SET/-58°F+SET	-50.0	Pr2
US	Maximum set point	SET+110°C / SET + 230°F	110	Pr2
O1	Thermostat probe calibration	-12-12°C / -120-120°F	0.0	Pr1
P2P	Second probe presence	n=not present; Y=pres.	n	Pr1
OE	Second probe calibration	-12-12°C / -120-120°F	0.0	Pr2
P3P	Third probe presence	n=not present; Y=pres.	n	Pr2
O3	Third probe calibration	-12-12°C / -120-120°F	0	Pr2
P4P	Fourth probe presence	n=not present; Y=pres.	n	Pr2
O4	Fourth probe calibration	-12-12°C / -120-120°F	0	Pr2
OdS	Outputs delay at start up	0-255 min	0	Pr2
AC	Anti-short cycle delay	0 - 50 min	1	Pr1
Ac1	Second compressor start delay	0-255s	5	Pr2
rtr	P1-P2 percentage for regulation	0 = 100 (100=P1, 0=P2)	100	Pr2
CCt	Continuous cycle duration	0.0-24.0h	0.0	Pr2
CCS	Set point for continuous cycle	(-55,0-150,0°C) (-67-302°F)	3.0	Pr2
COn	Compressor ON time with faulty probe	0 - 255 min	15	Pr2
COF	Compressor OFF time with faulty probe	0 - 255 min	30	Pr2
CH	Kind of action	cL=Ht	cL	Pr1
CF	Temperature measurement unit	°C + °F	°C	Pr2
rES	Resolution	in=integer; dE= dec.point	dE	Pr1
LoD	Probe displayed	P1-P2	P1	Pr2
rEdP	X-REP display	P1 - P2 - P3 - P4 - SE1 - dtr	P1	Pr2
dLy	Display temperature delay	0 - 20.0 min (10 sec.)	0.0	Pr2
dtr	P1-P2 percentage for display	1 - 99	50	Pr2
ACH	Kind of action for auxiliary relay	CL: Ht	cL	Pr2
SAA	Set Point for auxiliary relay	-50,0-110,0°C / -58-230°F	0,0	Pr2
SHy	Differential for auxiliary relay	0,1-25,5°C / 1-255°F	2,0	Pr2
ArP	Probe selection for auxiliary relay	nP / P1 / P2 / P3/P4	nP	Pr2
Sdd	Auxiliary relay operating during defrost	n=y	n	Pr2
ALP	Alarm probe selection	nP; P1; P2; P3; P4	P1	Pr2
ALC	Temperat. alarms configuration	rE= related to set; Ab= absolute	Ab	Pr2
ALU	MAXIMUM temperature alarm	Set+110,0°C; Set+230°F	110,0	Pr1
ALL	Minimum temperature alarm	-50,0°C+Set/-58°F+Set	-50,0	Pr1
AFH	Differential for temperat. alarm recovery	(0,1°C-25,5°C) (1°F-45°F)	2,0	Pr2

Label	Name	Range	Value	Level
ALd	Temperature alarm delay	0 ÷ 255 min	15	Pr2
dAO	Delay of temperature alarm at start up	0 ÷ 23h e 50'	1,3	Pr2
AP2	Probe for temperat. alarm of condenser	nP; P1; P2; P3; P4	P4	Pr2
AL2	Condenser for low temperat. alarm	(-55 ÷ 150°C) (-67 ÷ 302°F)	-40	Pr2
AU2	Condenser for high temperat. alarm	(-55 ÷ 150°C) (-67 ÷ 302°F)	110	Pr2
AH2	Differ. for condenser temp. alar. recovery	[0,1°C ÷ 25,5°C] [1°F ÷ 45°F]	5	Pr2
Ad2	Condenser temperature alarm delay	0 ÷ 254 (min.) , 255=nU	15	Pr2
dA2	Delay of cond. temper. alarm at start up	0.0 ÷ 23h 50'	1,3	Pr2
bLL	Compr. off for condenser low temperature alarm	n(0) - Y(1)	n	Pr2
AC2	Compr. off for condenser high temperature alarm	n(0) - Y(1)	n	Pr2
tbA	Alarm relay disabling	n=no; y=yes	y	Pr2
oA3	Third relay configuration	ALr = alarm; dEF = do not select it; Lig = Light; AUS = AUX; onF = always on; Fan = do not select it; db = neutral zone; cP2 = second compressor; dF2 = do not select it; HES = night blind	Lig	Pr2
oAP	Alarm relay polarity (oA3=ALr)	oP; cL	cL	Pr2
i1P	Digital input polarity (13-14)	oP=opening;CL=closing	cL	Pr1
i1F	Digital input 1 configuration (13-14)	EAL, bAL, PAL, dor; dEF; Htr, AUS	dor	Pr1
did	Digital input alarm delay (13-14)	0÷255min	15	Pr1
i2P	Digital input polarity (13-19)	oP=opening;CL=closing	cL	Pr2
i2F	Digital input configuration (13-19)	EAL, bAL, PAL, dor; dEF; Htr, AUS	EAL	Pr2
d2d	Digital input alarm delay (13-19)	0÷255min	5	Pr2
Nps	Number of activation of pressure switch	0 ÷ 15	15	Pr2
odc	Compress status when open door	no; Fan; CP; F_C	F-c	Pr2
rrd	Regulation restart with door open alarm	n - Y	y	Pr2
HES	Differential for Energy Saving	(-30°C ÷ 30°C) (-54°F ÷ 54°F)	0	Pr2
Adr	Serial address	1÷247	1	Pr2
PbC	Kind of probe	Ptc; ntc	ntc	Pr2
onF	on/off key enabling	nu, oFF; ES	oFF	Pr2
dP1	Room probe display	--	-	Pr2
dP2	Second probe display	--	-	Pr2
dP3	Third probe display	--	-	Pr2
dP4	Fourth probe display	--	-	Pr2
rSE	Real set point	actual set	-	Pr2
rEL	Software release	--	1.8	Pr2
Ptb	Map code	--	-	Pr2

* Only for model with real time clock

² Only for XW10L with X-REP output